

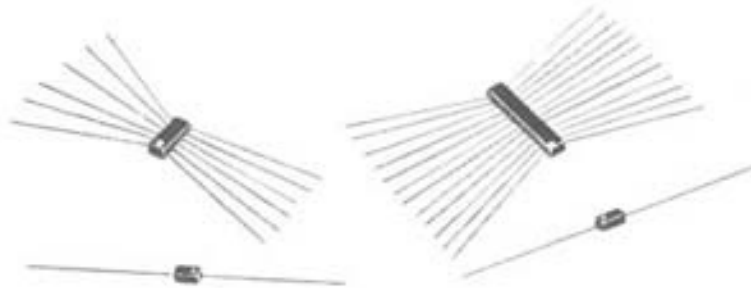

# NVD NVDX ARRAYS

## NIGHT VISION H.V. RECTIFIER DIODES & ARRAYS



These diodes and arrays have been specifically designed for use in night vision and image intensifier equipment power supplies. They offer unusual characteristics that have not been previously available. As a result of a proprietary EDI diffusion process, they feature small size and a unique combination of extremely low leakage and ultra fast recovery time.

Diode Specifications @ 23 °C (Absolute Maximum Unless Otherwise Specified)	NVDX Diode (Standard Recovery)	NVD Diode And Diode Arrays (Fast Recovery)
PRV	1,000 Vdc	1,200 Vdc
I <sub>F</sub>	5.0mA	5.0mA
V <sub>F</sub> @ 1 mA dc	6.0 V	4.0 V
Junction Capacitance	—————	0.35pF . @500 Vdc
I <sub>R</sub> @ 1,000 Vdc @ 23 °C	0.5 nanoamperes	—————
I <sub>R</sub> @ 1,000 Vdc @ 55 °C	5.0 nanoamperes	—————
I <sub>R</sub> @ 500 Vdc	—————	1.0 nanoamperes typical 5.0 nanoamperes max.
I <sub>R</sub> @ 500 Vdc @ 55 °C	—————	25 nanoamperes
I <sub>R</sub> @ 250 Vdc @ 23 °C	0.1 nanoamperes typical 0.25 nanoamperes max.	—————
I <sub>R</sub> @ 250 Vdc @ 55 °C	1.0 nanoamperes typical 2.0 nanoamperes max.	—————
T <sub>rr</sub> (Reverse Recovery Time), Fig.4	—————	50 ns typical 100 ns max.
Temperature Range: Operating	-55 °C to +100 °C	-55 °C to +100 °C
Temperature Range: Storage	-63 °C to +125°C	-63 °C to +125°C

EDI reserves the right to change these specifications at any time without notice.

# NVD NVDX ARRAYS

Figure 1  
NVDX

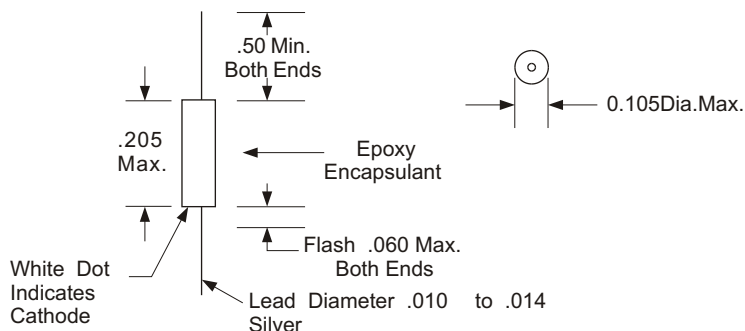

Figure 2  
NVD

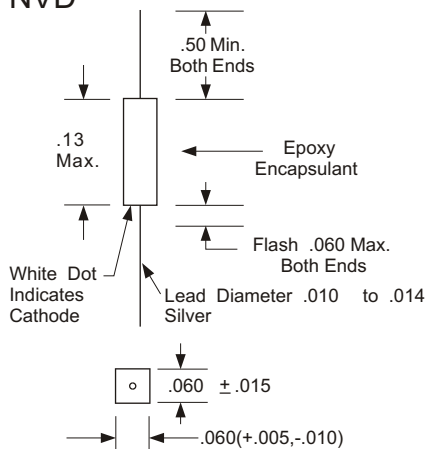
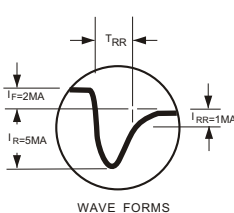

Figure 4

## REVERSE RECOVERY TEST METHOD

RECOVERY WAVEFORM



RECOVERY TEST CIRCUIT

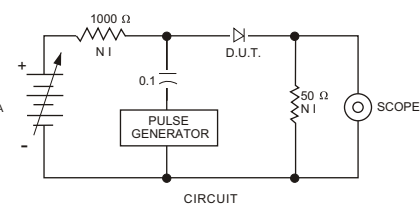
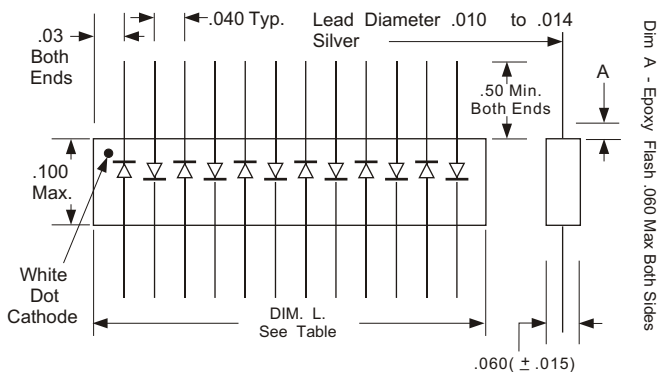

Figure 3  
NVD ARRAYS

PART NO.	NO. OF DIODES	DIM "L"
NVD - 1	1	SEE FIG.2
NVD - 2	2	.100 MAX
NVD - 4	4	.200 MAX
NVD - 6	6	.275 MAX
NVD - 8	8	.360MAX
NVD - 12	12	.515 MAX



EDI reserves the right to change these specifications at any time without notice.

**ELECTRONIC DEVICES, INC.** DESIGNERS AND MANUFACTURERS OF SOLID STATE DEVICES SINCE 1951.

21 GRAY OAKS AVENUE \* YONKERS, NEW YORK 10710 914-965-4400 \* FAX 914-965-5531 \* 1-800-678-0828

e-mail:sales@edidiodes.com \* website: http://www.edidiodes.com